

MODEL 62000B SERIES

KEY FEATURES

- Voltage range: 1 ~ 150V
- Current range: Up to 2000A (System)
- Power range up to 1.5KW per module up to 120KW per system
- High Power Density (464 mW / cm³ = 7.13 W/In³)
- N+1 Redundancy
- Hot-swappable
- Ideal for Burn-in & Plating
- Remote Sense
- Remote ON / OFF
- CAN Bus Control
- DC OK Signal Output



MODULAR DC POWER SUPPLY MODEL 62000B SERIES

Chroma's new 62000B series of Modular DC Power Supplies offer many unique features for Burn-in and plating/electrolysis applications. The features include a N+1 redundancy, high power densities, hot-swappable maintenance, remote ON/OFF and programmable control via the CAN bus.

The 62000B family offers 5 types of power module with ranging from 1V to 150V, current from 10A to 90A, and offers two mainframe type of six and three position. The six position mainframe can envelop in up to six power modules paralleled operation for 9KW power output. The 62000B can easily parallel up to fourteen mainframe to 120KW with current sharing and CAN bus control for bulk power applications.

The Modular DC Power Supplies of 62000B are very cost effective with high power density and low current ripple. These instruments have been designed for burn-in applications such as the LCD panels, DC-DC converters, power inverters, notebook computers, battery chargers and many other types of electronic devices.

Modern power factor correction circuitry is incorporated in 62000B providing an input power factor above 0.98 to meet the IEC requirements. This PFC correction circuitry not only reduces the input current draw and to greatly reduce generation of input current harmonics. Optional graphic Soft Panels and CAN bus control allow for control and monitoring of the power system using an easy to use graphical interface.



Chroma

HOT-SWAP OPERATION

Equipped with the functionality of N+1 redundancy and hot-swap, the 62000B Series of modular DC power supplies are most applicable for 24 hours non-stop applications such as the SMD plating production lines, as well as product life burn-in test for IT products like DC converters, LCD backlight inverters and routers.

For continuous operation applications the modular hot-swap design allows engineers to replace the failure unit on-site without shutting down the entire system.



HIGH POWER APPLICATIONS WITH CSU

The 62000B modular power supplies are capable of providing high power output up to 120KW/2000A with minimal specification degradation via CSU(Control & Supervisor Unit). Each chassis is designed to accommodate a maximum of 9KW and include current sharing capability to ensure system stability. In addition, for convenient control of even large power systems, a CSU is provided to set and display output and protection circuits via a standard CAN bus communication protocol.

Available Power Ratings

Current Rating \ Power Rating	9KW	18KW	27KW	36KW	45KW
Voltage Rating					
15V	540A	1080A	1620A	2160A	2700A
30V	300A	600A	900A	1200A	1500A
60V	150A	300A	450A	600A	750A
80V	108A	216A	324A	432A	540A
150V	60A	120A	180A	240A	300A
Paralleled unit of mainframe	1	2	3	4	5

Note: Contact the factory for more information on customization of high power system (>2000A).

A620007 CSU Key Features:

- Stand-alone controller for paralleled 62000B DC power for bulk power
- Digital encoder knobs and function keys
- Simultaneous display of output voltage and current
- Standard Analog programmable interface
- Standard CAN Bus
- Optional Ethernet interface
- User define I/O interface
- Controller up to 14 mainframes



A620007 Control & Supervisor Unit



CAN BUS'S ADVANTAGES

Controller Area Network (CAN) is a multicast shared, differential serial bus standard. CAN was specifically designed to be robust in electromagnetically noisy environments and can utilize a differential balanced line like RS-485. Introduced by Bosch in 1986 for in-vehicle networks in cars, it is used in myriad applications including factory automation, building automation, aircraft and aerospace as well as in cars, trucks and buses. CAN bus replaced bulky wiring harnesses with a two-wire differential cable. CAN provides services at layers 1 and 2 of the OSI model and uses a broadcast method for placing frames on the wire. CAN provides low-speed, fault-tolerant transmission of 125 Kbps up to 40 meters, which can function over one wire if a short occurs. Transmission without fault tolerance is provided up to 1 Mbps and 40 meters, and distances up to 1 km are achieved with bit rates of 50 Kbps. Bit rates up to 1 Mbit/s are possible at network lengths below 40m. Decreasing the bit rate allows longer network distances (e.g. 125 kbit/s at 500 m).

PANEL DESCRIPTION

Model 62000B Series

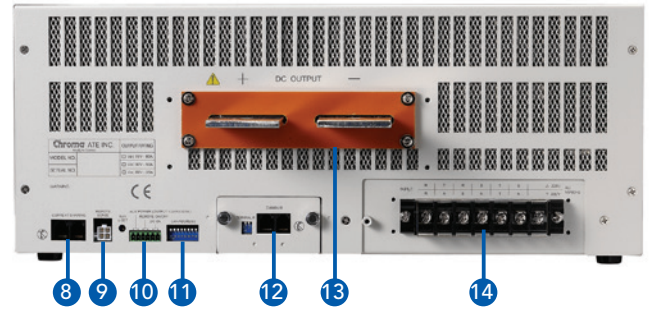
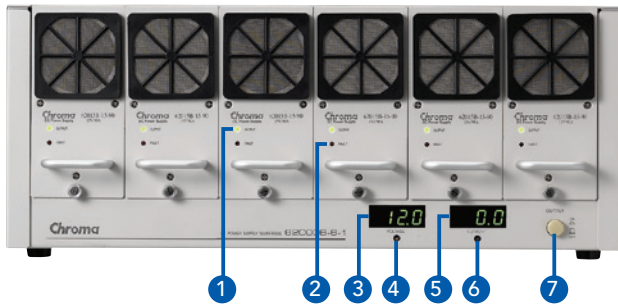

FRONT PANEL

1. OUTPUT ENABLED LED
2. FAULT INDICATOR
3. OUTPUT VOLTAGE READOUT
4. VOLTAGE TRIMMER (1V-100%)
5. OUTPUT CURRENT READOUT
6. CURRENT TRIMMER (1A-100%)
7. OUTPUT ENABLE/DISABLE SWITCH

REAR PANEL

8. CURRENT SHARING CONNECTOR (FOR MAINFRAME)
9. REMOTE SENSE CONNECTOR
10. I/O CONNECTOR (INCLUDES REMOTE ON/OFF, DC OK, AUX POWER)
11. CAN DIP ADDRESS SWITCH
12. CAN BUS COMMUNICATIONS PORT (OPTIONAL)
13. OUTPUT TERMINALS
14. AC INPUT TERMINAL BLOCK

Model A620007

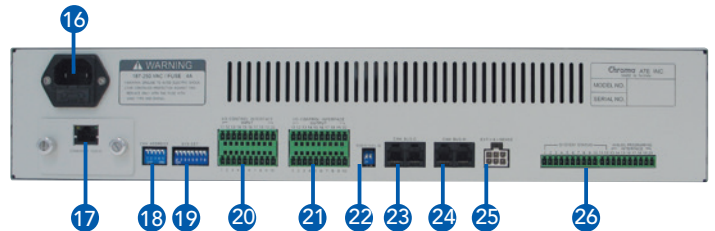
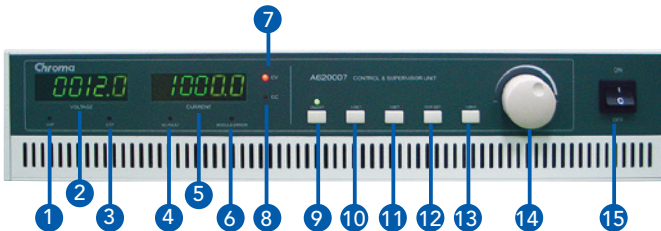

FRONT PANEL

1. OVP INDICATOR
2. VOLTAGE READOUT
3. OTP INDICATOR
4. AC-FAULT INDICATOR
5. CURRENT READOUT
6. MODULE ERROR INDICATOR
7. CV MODE INDICATOR
8. CC MODE INDICATOR
9. ON/OFF ENABLE/DISABLE
10. V-SET BUTTON
11. I-SET BUTTON
12. OVP-SET BUTTON
13. I-MAX LIMITED SETTING
14. ROTARY
15. AC ON/OFF SWITCH

REAR PANEL

16. AC INPUT
17. ETHERNET
18. CAN ADDRESS SET
19. DIP SWITCHING FOR SYSTEM SETTING
20. I/O CONTROL INTERFACE INPUT
21. I/O CONTROL INTERFACE OUTPUT
22. TERMINAL-RESISTANCE (CAN)
23. CAN BUS to PC
24. CAN BUS to MAINFRAME
25. EXT-V&I SENSE INPUT
26. APG CONTROL

SOFTPANEL

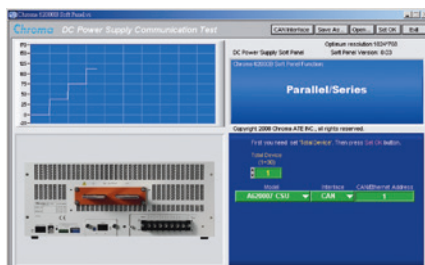

Main Operation Menu

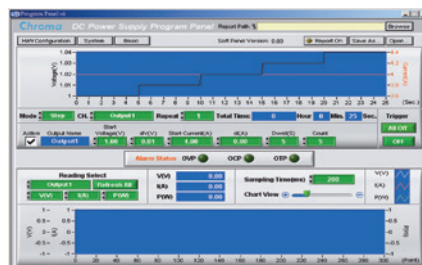

Program Sequence Function

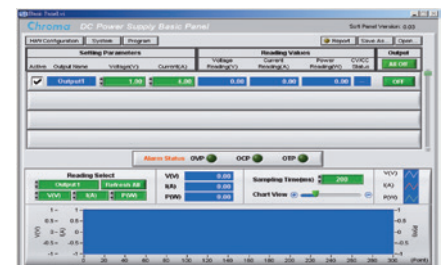

Basic Control Function for 30 Channels

CONTROL METHOD FOR PARALLELED

Type A - Control with CSU : User can control via APG, CAN Bus/ Ethernet, and front panel manual control for paralleled operation.

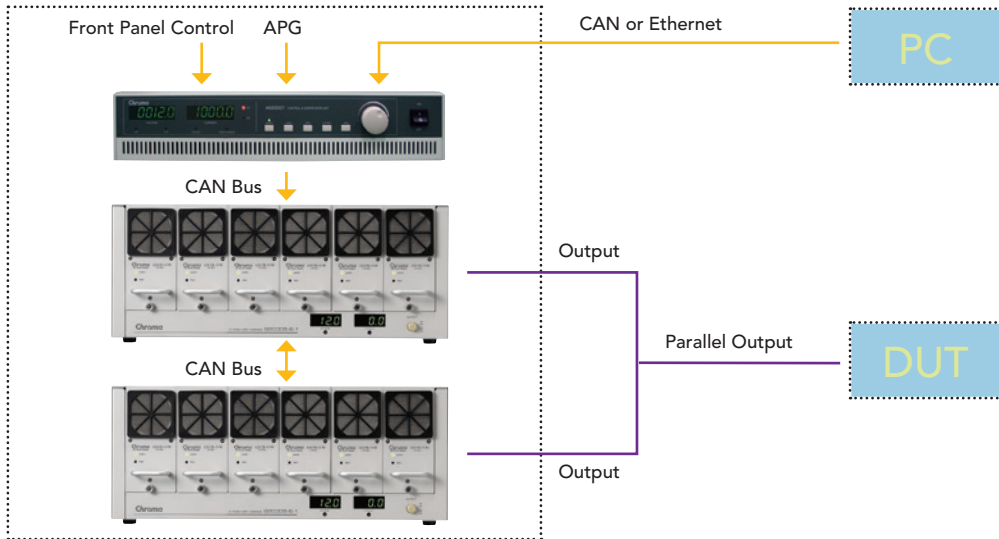

Type B - Control without CSU : User can only control via CAN Bus for paralleled operation.

Note: The SoftPanel can control four mainframes for paralleled operation.

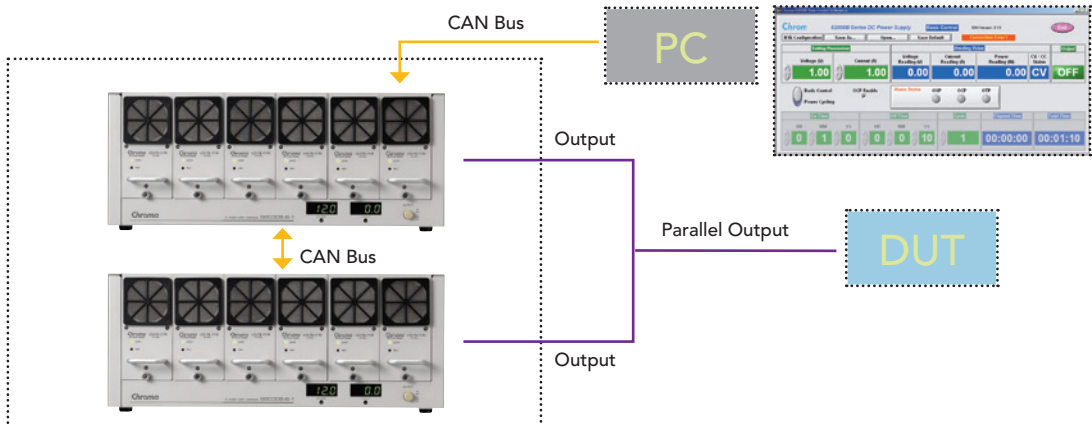

Type C - Control without CSU or PC : User can only control via remote on/off signal for paralleled operation.

Note 1 : User can NOT adjust the output voltage when parallel the output.

Note 2 : The output voltage will fixed in factory default voltage.

Note 3 : If need to adjust the output voltage, please adjust when stand alone.

Note 4 : Time delay from output enable until output stable: 10s max.

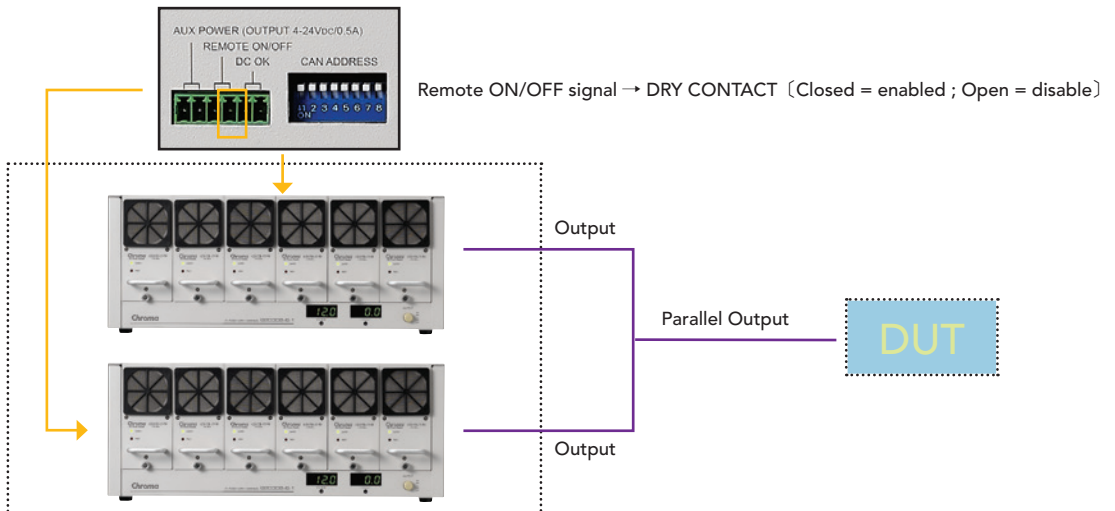

SPECIFICATIONS

Model	62015B-15-90	62015B-30-50	62015B-60-25	62015B-80-18	62015B-150-10
Electrical Specifications					
Output Ratings					
Output Power	1350W	1500W	1500W	1440W	1500W
Output Voltage	1~15V	1~30V	1~60V	1~80V	1~150V
Output Current	1~90A	1~50A	1~25A	1~18A	1~10A
Line Regulation	0.1% F.S.				
Load Regulation *1	1% F.S.				
Programming Accuracy	1% F.S.				
Measurement Accuracy	1% F.S.				
Output Noise (20MHz)					
Voltage Noise (P-P)	100mV	100mV	200mV	200mV	400mV
Voltage Ripple (rms)	30mV	30mV	50mV	50mV	100mV
Current Ripple (rms)	0.9A	0.5A	0.25A	0.18A	0.1A
Efficiency	> 85% @ full load	> 88% @ full load			
Turn on over shoot voltage *2	5% of nominal output				
Transient Response Time *3	< 5 ms				
AC Input Voltage					
Six Position Mainframe	3Ø 200~240Vac ± 10% V _{LL} or 3Ø 380~400Vac ± 10% V _{LL} , 47~63 Hz				
Three Position Mainframe	1Ø 200~240Vac ± 10% V _{LN} , 47~63 Hz				
Input Power Factor	> 0.98@ full load				
Protection Function					
OVP	Automatically shuts down at 115% of set value				
Adjustment Range	1~16V	1~31V	1~65V	1~83V	1~155V
OCP	Current limit (0 ~ 100%) / OCP Shutdown at 115% of F.S.				
OTP	Automatically shuts down if internal limit is reached				
I/O Signal					
Remote ON/OFF (I/P)	Dry contact (closed = enabled), vice versa				
AUX Voltage	4 ~ 24V / 0.5A at mainframe (by trimmer adjust voltage)				
DC OK Signal Type (O/P)	Dry contact (closed = enabled) (Error : OVP / OCP / OTP / AC Fault)				
Programming Response Time *4 (Typical)					
Rise Time (Full Load)	For a programmed 5% to 95% step in output voltage : 100ms				
Rise Time (No Load)	For a programmed 5% to 95% step in output voltage : 100ms				
Fall Time (Full Load)	For a programmed 95% to 5% step in output voltage : 40ms				
Fall Time (No Load)	For a programmed 95% to 5% step in output voltage : 5s				
Vout Setting	CAN BUS send command to DC module receiver : 1s				
Measurement V & I	Under CAN command using fetch : 100ms				
Delay Time	For output ON/OFF enable and disable (under CAN command) : 5s(Single Mainframe)				
General Specifications					
Remote Sensing	3V max. line loss compensation				
Parallel Operation	Current Sharing (± 5%)				
Operating Temperature	0 ~ 50°C				
Humidity Range	0 ~ 90% RH. Non-condensing				
Remote Interface	CAN BUS (optional)				
Safety & EMC	CE				
Dimension (H x W x D)	Mainframe : 175.6 x 443.9 x 466.2 mm / 6.91 x 17.48 x 18.35 inch (62000B-6-1) Mainframe : 175.6 x 239.9 x 466.2 mm / 6.91 x 9.44 x 18.35 inch (62000B-3-1) Module : 138.5 x 67.5 x 377.5 mm / 5.45 x 2.66 x 14.86 inch				
Weight	Mainframe : 14 Kg / 30.8 lbs (62000B-6-1) Mainframe : 8 Kg / 17.6 lbs (62000B-3-1) Module : 4 Kg / 8.8 lbs				

All specifications are subject to change without notice. Please visit our website for the most up to date specifications.

Note*1 : For 50% step load variation with remote sense at maximum output voltage

Note*2 : based on rise time of 100ms

Note*3 : Time for the output voltage to recover within 1% of its rated for a load changed of 25%

Note*4 : Six Position Mainframe through CAN

SPECIFICATIONS

A620007 Control & Supervisor Unit	
Setting Item	Output voltage setting (V set + Rotary)
	Output current limit setting (I set + Rotary)
	Over voltage protection setting (OVP_SET) (Default : 115% Vmax.)
	Output ON/OFF
	OCP selection : CC mode or Shutdown (By Dip switch selection at rear panel)
Measurement Display Item	Max. output current setting (I max)
	Output voltage display (7 segment LED)
	Output current display (7 segment LED)
	Operating mode indicator : CV or CC
	Output ON/OFF indicator
Alarm Indicator Item	Max. output current display (I max button)
	CSU : Over voltage protection
	CSU : Over temperature protection
	AC fault alarm
Power module fault alarm	
Remote Control Interface	
CAN Bus	Standard
Ethernet	Optional
Analog Programming Interface (Standard)	Setting voltage (A/I) : 0-10Vdc or 0-1 mA of FS (Resolution : 12 bits, Accuracy : 1% FS) Setting current (A/I) : 0-10Vdc or 0-1 mA of FS (Resolution : 12 bits, Accuracy : 1% FS) Monitor voltage (A/O) : 0-10V of FS (Resolution : 12 bits, Accuracy : 1% FS) Monitor current (A/O) : 0-10V of FS (Resolution : 12 bits, Accuracy : 1% FS)
Remote Output ON/OFF	Dry contact
Output ON/OFF Indicator	Active High
CV or CC mode Indicator	TTL Level High=CV mode ; TTL Level Low=CC mode
OTP Indicator	Active High
System Fault Indicator	Active High
I/O Control Interface	I/O : I/P=10 , O/P=10
I/P Definition	
Pin 1 & 2	Temperature sensor for bulk power system rack A (Active : open / default : short)
Pin 3 & 4	Temperature sensor for bulk power system rack B (Active : open / default : short)
Pin 5 & 6	Emergency stop for bulk power system
Pin 7~20	Reserved
O/P Definition	
Pin 1 & 2	OVP
Pin 3~20	Reserved
AC Input Voltage	Single phase 187-253VAC
Dimension	High(2U) x width(19")

All specifications are subject to change without notice. Please visit our website for the most up to date specifications.

ORDERING INFORMATION

62000B-3-1 : Three Position 62000B Mainframe
 62000B-6-1 : Six Position 62000B Mainframe
 62015B-15-90 : DC Power Supply Module, 15V/90A/1350W
 62015B-30-50 : DC Power Supply Module, 30V/50A/1500W
 62015B-60-25 : DC Power Supply Module, 60V/25A/1500W
 62015B-80-18 : DC Power Supply Module, 80V/18A/1440W
 62015B-150-10 : DC Power Supply Module, 150V/10A/1500W
 A620007 : Control & Supervisor Unit
 A620008 : CAN Bus Interface for mainframe
 A620010 : Rack Mounting Kit for mainframe
 A620011 : Ethernet Interface for CSU
 A620012 : AD-Link PCI 7841 CAN Bus Card
 A620013 : 19" Rack (23U) for 62000B Series
 A620014 : 19" Rack (41U) for 62000B Series

A620016 : Rack Mounting Kit for CSU
 A620017 : Softpanel for 62000B Series
 A620018 : NI USB-8473 high-speed USB to CAN interface
 A620019 : USB Interface Control Box for mainframe & CSU
 A620020 : GPIB Interface Control Box for mainframe & CSU
 A620021 : APG Interface Control Box for mainframe
 A620022 : RS-485 Interface Control Box mainframe & CSU

Get more product and global distributor information in Chroma ATE APP



iOS



Android

Search Keyword

62000B

HEADQUARTERS
 CHROMA ATE INC.
 88 Wenmao Rd.,
 Guishan Dist.,
 Taoyuan City
 333001, Taiwan
 T +886-3-327-9999
 F +886-3-327-8898
 www.chromaate.com
 info@chromaate.com

U.S.A.
 CHROMA SYSTEMS
 SOLUTIONS, INC.
 19772 Pauling,
 Foothill Ranch,
 CA 92610
 T +1-949-600-6400
 F +1-949-600-6401
 www.chromausa.com
 sales@chromausa.com

EUROPE
 CHROMA ATE
 EUROPE B.V.
 Morsestraat 32,
 6716 AH Ede,
 The Netherlands
 T +31-318-648282
 F +31-318-648288
 www.chroma.eu.com
 salesnl@chromaeu.com

CHROMA GERMANY GMBH
 Südtiroler Str. 9, 86165,
 Augsburg, Germany
 T +49-821-790967-0
 F +49-821-790967-600
 www.chroma.eu.com
 salesde@chromaeu.com

JAPAN
 CHROMA JAPAN
 CORP.
 888 Nippa-cho,
 Kouhoku-ku,
 Yokohama-shi,
 Kanagawa,
 223-0057 Japan
 T +81-45-542-1118
 F +81-45-542-1080
 www.chroma.co.jp
 info@chroma.co.jp

KOREA
 CHROMA ATE
 KOREA BRANCH
 3F Richtogether
 Center, 14,
 Pangyoyeok-ro 192,
 Bundang-gu,
 Seongnam-si,
 Gyeonggi-do
 13524, Korea
 T +82-31-781-1025
 F +82-31-8017-6614
 www.chromaate.co.kr
 info@chromaate.com

CHINA
 CHROMA ELECTRONICS
 (SHENZHEN) CO., LTD.
 8F, No.4, Nanyou Tian
 An Industrial Estate,
 Shenzhen, China
 T +86-755-2664-4598
 F +86-755-2641-9620
 www.chroma.com.cn
 info@chromaate.com

SOUTHEAST ASIA
 QUANTEL PTE LTD.
 (A company of Chroma Group)
 25 Kallang Avenue #05-02
 Singapore 339416
 T +65-6745-3200
 F +65-6745-9764
 www.quantel-global.com
 sales@quantel-global.com