

Chroma Systems Solutions, Inc.

Leakage Current – Part 1

19032 Series Electrical Safety Analyzer

Keywords: Leakage Current, Earth Line Leakage, Touch/Chassis (Enclosure) Leakage, Patient Leakage, Patient Auxiliary Current, Class I Product, Class II Product, IEC60601-1.

Title:

Leakage Current Part 1

Product Family: 19032 Series Electrical Safety Analyzer

The measurement of leakage current is one of the most important tests in electrical safety testing. Leakage current is often misunderstood because it is not a common production test, like the dielectric withstand (hipot) test that is required on all mains power products. Plus there are multiple types of leakage current that must be tested in devices with multiple leads. With the exception of medical products, leakage current tests are not normally required in production.

However, the measurement of leakage current is a requirement for type testing of any mains powered product. A compliance laboratory or National Recognized Test Lab (NRTL) normally performs the type testing on a sample of products during the design phase. Once the type testing is complete generally no further leakage testing is required on a production basis with the exception of medical products. Leakage current measurements are routinely performed on the production line for medical products for safety reasons.

A simple illustration of leakage current is if a person comes in contact with a product that is operating how much current flows from the point where the person came in contact with the product through the person's body and back to ground or some other point. Does this mean that anytime you touch a product that current might be flowing through you body? Some level of current will be flowing through you body especially on products with a two-prong power cord. If this current is very low (<0.5mA) a typical adult will not notice the current. A shock could result if a person was exposed to leakage current levels exceeding 0.5mA.

There are several different types of leakage current: Earth Line Leakage, Touch/Chassis (Enclosure) Leakage, Patient Leakage, and Patient Auxiliary Current. Each one of these will be discussed in further detail later. The basic differences between leakage currents depend upon how a person might come in contact with the product or the measurement. For example the leakage that would flow through a person's body if they touched the outside enclosure of a product would be Touch/Chassis (Enclosure) leakage.

NOTE:

The terminology used in this article (such as Touch/Chassis for Enclosure) is in harmonization with IEC60990. This terminology has been incorporated into the third edition of IEC60601-1.

What is a safe level of leakage current?

Depending on the type of equipment, acceptable levels of leakage current have been determined and are generally outlined in the appropriate international or regional standard. Acceptable levels of leakage current are dependent on the classification of the particular type of equipment. The basic principle behind protection against electrical shock is to have at least two levels of protection.

Class I Product

Class I products use Basic Insulation in combination with Protective Earth. These products will have a three-prong power cord and the ground blade will be attached to any accessible metal on the product.

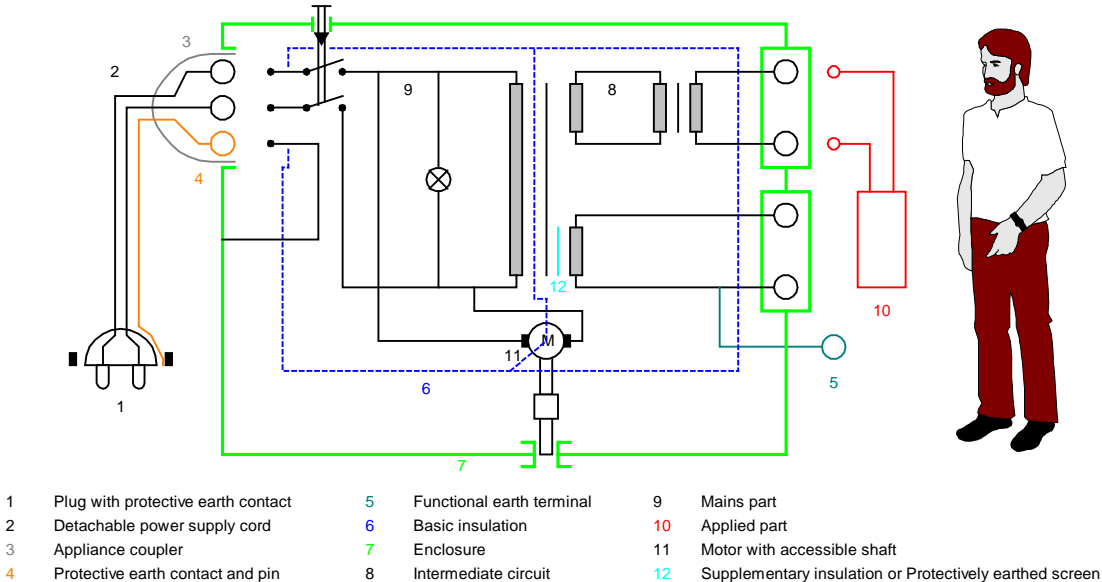

Figure 1: Class I product Figure 3 from IEC60601-1

Refer to Tables 1 and 2 for some example limits from international standard IEC60601-1. Refer to Definitions at end of article. Table 1 lists leakage current limits for the Applied Part by part type and fault simulation. Table 2 lists limits for Enclosure and Earth Leakage tests by fault simulation.

Table 1: Example Patient and Auxiliary Patient Leakage Limits

	Applied Part					
	Type B		Type BF		Type CF	
	Normal	Single Fault	Normal	Single Fault	Normal	Single Fault
DC Current	10µA	50µA	10µA	50µA	10µA	50µA
AC Current	100µA	500µA	100µA	500µA	10µA	50µA
Reference Supply Voltage on Applied Part			5000µA		50µA	

Table 2: Example Touch/Chassis and Earth Leakage Limits

Leakage Test	Normal	Single Fault
Touch/Chassis (Enclosure)	100µA	500µA
Earth (permanently attached power cord)	5mA (Max Limit)	10mA (Max Limit)
Earth	0.5mA	1mA

Class II Product

Products that have a two-prong power cord are Class II products. Class II products rely not only on basic insulation but also supplemental insulation or reinforced insulation. These products are often referred to as double insulated products as protection against shock relies on two layers of insulation.

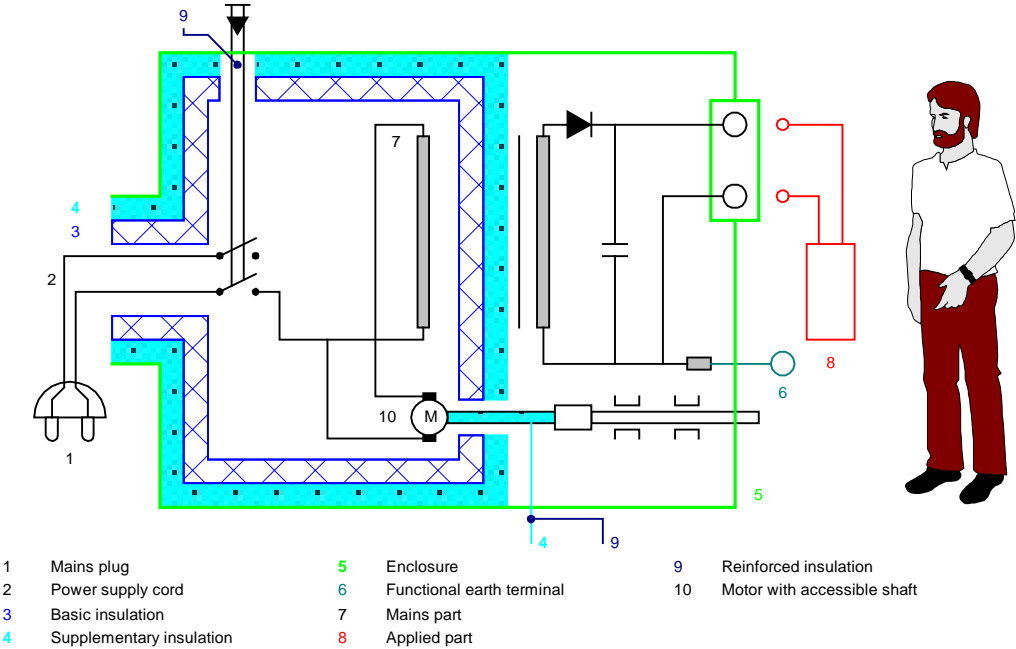

Figure 2: Class II product Figure 4 from IEC60601-1

Measurement of Leakage Current

Leakage current is measured to ensure that the electrical insulation provides adequate protection against electrical shock. The tests are designed in such a way as to simulate a human body coming in contact with different parts of the product and then measuring the leakage current flowing through a simulated human body model or network. The measured leakage current values are then compared with acceptable limits based upon the type of product being tested (class), point of contact with the product (Earth, Touch, Patient) and operation of the product under normal and single fault conditions. Refer to Definitions at end of article.

The leakage current measurements are performed with the product energized and in all conditions such as standby and full operation. The mains supply voltage is normally delivered via an isolation transformer to the product. The mains supply voltage should be at 110% of the highest rated supply voltage and at rated supply frequency. This means that a product rated for operation at 115VAC 60Hz and 230VAC 50Hz would be tested at 110% of 230VAC that equals 253VAC and at a line frequency of 60Hz.

Measurement of Leakage Current

The measuring instrument referred to as **MD** shall have an input impedance $\geq 1\text{M}\Omega$ and a frequency characteristic that is flat from DC to 1MHz. The instrument shall indicate the true R.M.S. value of the voltage across the measuring impedance or the current flowing through the measuring device with an indicating error not exceeding $\pm 5\%$. The instrument shall also load the source of the leakage current with an impedance of approximately 1000Ω for frequencies from DC to 1MHz. This is accomplished by using a human body model or network attached to the input of the measuring instrument. Depending upon the standard being used the impedance of the human body model or network will change. Figure 3 shows a human body model or network used in IEC60601-1. There are a number of commercially available instruments that are specifically designed to perform leakage current measurement. These instruments have all of the correct accuracy, input impedance and typical selectable human body models for several popular standards built right in to the instrument.

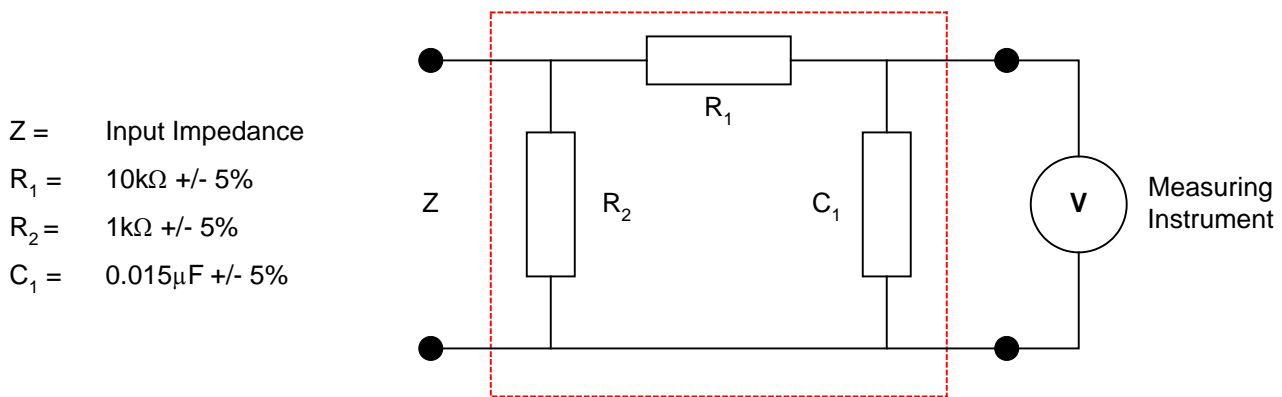

This figure is equivalent to  in IEC60601-1 Leakage Circuit Diagrams

Figure 3: Human Body Model or Network for IEC60601-1

Leakage currents are measured during both normal operation and fault conditions. Normal operation means the product energized in both standby and full operation. In most cases, medical devices also have the requirement for connection of any voltage or current permitted under normal operation to the signal input and output parts. Single fault conditions include opening of protective ground and opening of the neutral conductor on the mains supply. There can be additional fault conditions depending upon the design of the product.

There are some general rules that should be followed when performing a leakage current measurement. The product being tested should be placed on an insulating surface and significantly far away, 20cm, from any earthed metal surface. The measurement circuit and cables should be positioned as far away from unscreened power supply leads as possible and significantly far away from any earthed metal surface.

Definitions

Applied Part:	Part of the medical product that in normal use comes in contact with the patient. They are often referred to as patient connections. There are three types of applied parts; B, BF and CF. They are classified based upon usage C being cardiac versus non-cardiac and F being floating/isolated from earth ground.
B-Type Applied Part:	B-Type applied parts are non-cardiac grounded applied parts. These are applied parts that come in contact with the patient for the medical device to perform its function. B-type parts are referenced to ground and are not isolated or 'floating' as would be the case in BF or CF applied parts.
Basic Insulation:	Insulation providing basic protection against electrical shock.
Class I Product:	Product that use Basic Insulation in combination with an additional safety level of using Protective Earth. Class I products have a three prong power cord.

Class II Product:	Product that relies not only on basic insulation but an additional safety level of supplemental Insulation or Reinforced insulation. Class 2 products typically have a two-prong power cord.
Double Insulation:	Insulation comprising of both Basic Insulation and Supplemental Insulation. (Symbol of double insulated product )
Earth Leakage Current:	The leakage current from all earthed parts of the product. The current flowing from the mains supply through or across insulation into the Protective Earth Conductor.
F-Type Applied Part:	An F-Type applied part is isolated to such a degree that no current higher than the allowable patient leakage current under a Single Fault Condition flows into it from an application of external voltage source to the patient. F-Type Applied Parts are classified as BF (non-cardiac floating applied parts) or CF (cardiac floating applied parts). These parts are tested by applying 110% of the mains supply voltage from an isolation transformer to the F-Type AP then measuring the patient leakage current between the isolation transformer and the F-Type AP.
Leakage Current:	General term for Earth Leakage Current, Touch/Chassis/Enclosure Leakage Current and Patient Leakage Current. Leakage current is generally not desirable from an electrical safety standpoint.
Patient Auxiliary Current:	Current flowing between patient connections and that is not intended to be there to produce an effect in the patient.
Patient Leakage Current:	The current flowing from every individual part of the applied part back to earth or the current flowing from an unintended appearance of a voltage on the patient back to an F-Type Applied Part.

Protective Earth: Conductor that connects between any protectively earthed parts of a Class I product and an external protective earth connection.

Reinforced Insulation: A single system of insulation that provides two levels of protection against electrical shock.

Signal Input/Output Part: (SIP/SOP) Part of the medical product that is not an Applied Part but is intended to send or receive signals from other external equipment. If mains voltage is accidentally applied to a signal I/O part due to a fault in the external equipment, what is the effect on patient leakage current?

Single Fault Condition: Condition in which a single means of electrical safety protection is defective or an abnormal condition is present. Examples of a single fault condition would be interruption of the ground conductor on a Class I product or opening of the neutral supply conductor to the product.

Supplemental Insulation: Independent insulation applied in addition to Basic Insulation in order to provide protection against electrical shock in the event of a failure of Basic Insulation.

Touch/Chassis Leakage: Leakage Current from the enclosure or other parts, excluding applied parts that are not connected to a protective earth conductor.

This installment (#6) of the IEC60601-1 Series has defined leakage current and illustrated the two product classes of electronic medical devices. Tune in next time when the discussion will detail the IEC60601-1 measurement circuits for Earth, Enclosure and Patient Leakage Tests.



Application Note

Leo@EisnerSafety.com. Eisner Safety Consultants specializes in assisting clients with product evaluation to safety standards, Agency coordination, CE Mark, Quality Systems and training.

For complete product specifications on the 19032 Series Electrical Safety Analyzers or any of Chroma's products, visit us at www.Chromausa.com. Do you have an application specific testing need? Call us at 978-461-2100 for east coast, 949-600-6400 for west coast or email your questions to sales@chromausa.com.

The information presented in this application note is subject to change and is intended for general information only.