

Electrical Safety Analyzer

MODEL 19032/19032-P

Key Features :

- AC/DC/IR/GB/LC five instruments in one
- Function test up to 20A
- Programmable voltage output and limit value
- OSC open/short check
- Flashover detection
- Human protection circuit
- Multi-scan device support dynamic leakage current test
- Standard RS232 interface
- Optional GPIB interface
- Large LCD panel
- Front panel lockout function
- Support PC software
- UL/TUV/CE



ELECTRICAL SAFETY ANALYZER

MODEL 19032/19032-P

General Electrical Safety Testing Solution

Electrical safety testing is the main item in electrical product quality test. All electrical products consist of Adapter, SMPS, Charger, House Appliance, Information technology product and Video product to perform electrical safety tests are required.

The 19032 series combines Hi-Pot, IR, GB, LC/ALC/DLC and Dynamic Function Test. The 19032 can reduce the space waste for 50% on manufacturing thus purchase more than one Hi-Pot tester isn't required. However, the 19032 be able to promote the efficiency of electrical safety testing on manufacturing in order to reduce risk on testing.

Open/Short Check (OSC)

Patent No. : 254135

All manufacturers have to solve the issues of error connection and test cable unconnected.

Chroma 19032 equipped with up-to-date open/

short check function (OSC) for products testing.

Twinport TM Function

USA Patent No.: US6504381

The key factor affects the efficiency of manufacturing is the efficiency for electrical safety testing. Twinport function can lower the time of safety test, the safety workstation won't be a bottleneck in production line any longer.

Product Application

The 19032 can apply to versatile tests of electrical products includes quality assurance sampling inspection test, manufacturing test and development validation.

- Power cord
- Adapter, SMPS
- House appliance
- Information technology product
- Medical equipment
- Lab/testing equipment
- EMI FILTER



Chroma



SAFETY TEST OF INFORMATION TECHNOLOGY PRODUCT (IEC 60950)

In digital time, information technology is close to our life. Desktop, notebook, LCD monitor, UPS, printer and projector that human may contact at any time. For ensure the safety of users, all products should do electrical safety testing. The 19032 offers all functions of safety test and Normal/Reverse as well as Single Fault switch function (LC Test) to reduce the load of manufacturing personnel.

Besides, output Floating of Telecommunication Network in IEC 60950 to perform dynamic leakage current test is required. The equivalent stray capacitance will also be generated on isolated transformer even it is Floating circuit. The stray capacitance results in leakage current, electrical hurt to users. The 19032 along with 6000-05 /07/08 leakage current scanner have P1/P2 measurement function which be able to measure dynamic leakage current on output terminal. It is the best solution for your testing on information technology product.

Main Test Item

- Open Short Check
- Ground Bond
- AC/DC Hipot Test
- Earth Leakage Current Test
- Output Leakage Current Test

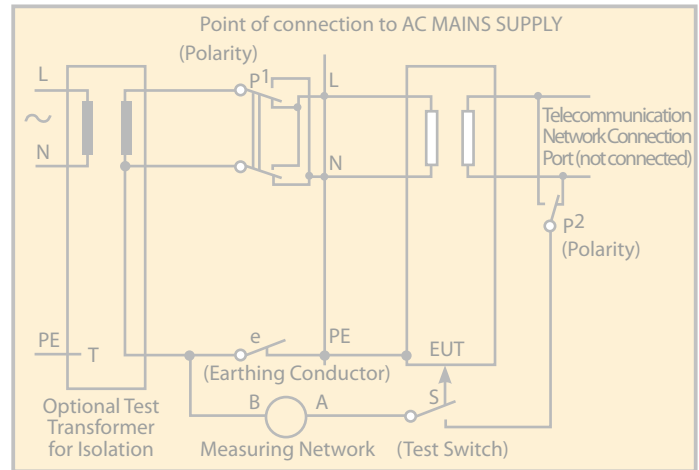
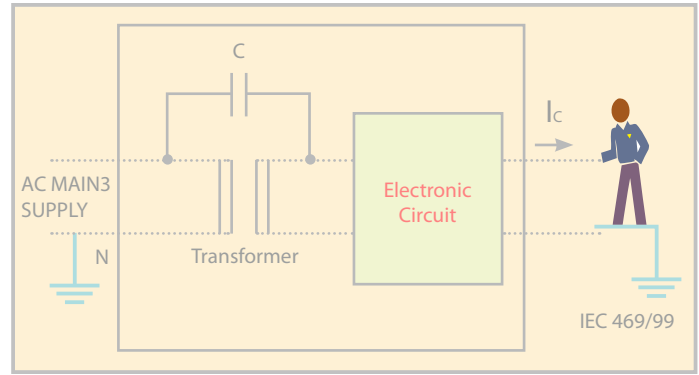

POWER SUPPLIES, ADAPTER AND CHARGER SAFETY TESTING

Power supply of electronic products are inclusive of SMPS, Adapter and charger that need to perform electrical safety test. According to various power design methods and test conditions, the 19032 offers programmable edit and solution to let you complete all tests at one time.



A lot of designs of power product, the insulation capability of input terminal (Primary) to output terminal (Secondary) is required to protect the damage inside component. Thus, the output terminal of Floating needs to perform Hipot test. The 19032 provides isolation test point with high voltage to let you no need to change fixture or cable by manually that performs P-S Hipot test directly after P-G Hipot test.

Moreover, if there is the danger can be touched at output terminal (Secondary), dynamic leakage current test also need to be performed.

Test Item	Open/Short Check	Ground Bond	P-G Hipot Test	P-Case Hipot Test	P-S Hipot Test	S-case Hipot Test	Earth Leakage Current Test	Output Leakage Current Test
Design Method								
No Floating Ground	V	V	V	-	-	-	V	V
With Grounded output & Floating Ground output	V	V	V	-	V	V	V	V
No Ground Lead	V	-	-	-	V	-	-	-
Plastic sealed and three line input (part design will use a connection line with chock between the secondary ground and the primary ground)	V	-	-	V	V	-	-	-

SAFETY TEST OF VIDEO PRODUCT (IEC 60065)

Video products are inclusive of DVD recorder, LCD TV, audio amplifier, stereo and etc. These products have mass power output thus separately safety standards shared. The mainly circuit design of mass power is signal output terminal except temperature increasing and heat dissipation of electronic component. Open voltage of some video products are over 35Vac peak or 60Vdc peak that performs U1 dynamic leakage current test is required. U1 measurement circuit is added to the 19032 and P1/P2 measurement point provided that comply with the requirement of safety standard test.

Main Test Item

- Open Short Check
- Ground Bond
- AC/DC Hipot Test
- Earth Leakage Current Test
- Output LC Test

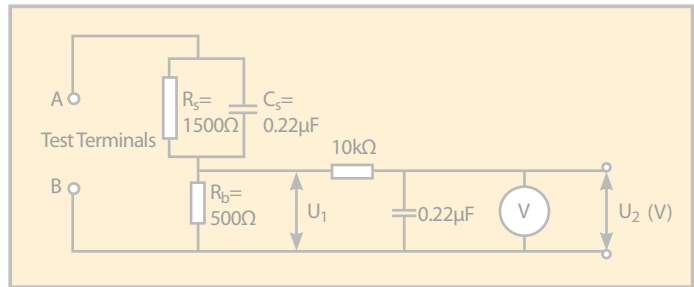

SAFETY TEST OF HOUSE APPLIANCE (IEC 60335)

House appliance consists of oven, refrigerator, television, juicer and coffee machine that human may contact at any time. For ensure the safety of users, all products should do electrical safety testing. Except basic Hipot test, dynamic leakage current has various test regulations by different ground mode and operation method. About the regulations are as below table shown.

Main Test Item

- Open Short Check
- Ground Bond
- AC/DC Hipot Test
- Earth Leakage Current Test

for Class II appliances	0.25mA
for Class 0, Class 0I and Class III appliances	0.5mA
for Portable Class appliances	0.75mA
for Stationary Class Moto-Operated appliances	3.5mA
for Stationary Class Heating appliances	0.75mA or 0.75mA per kW rated power input of the appliances with a maximum of 5 mA, whichever is higher

SAFETY TEST OF MEDICAL EQUIPMENT (IEC 60601)

19032 + 6000-07 is a solution for electrical safety and function test of medical equipment. The safety standard of medical equipment is very strict. Because the medical equipment keeps in touch with the health of the doctor and patient frequently, make several electrical safety tests can't be ignored especially leakage current test which has already become the most important test in electrical safety test.

The safety standard of medical equipment has various of leakage current tests. Additionally, normal / reverse / single fault normal / single fault reverse four powers and earth switch, let medical equipment safety test difficulty and complexity further. The basic measuring circuit for the enclosure leakage current as below figure. In addition to measuring Type BF and CF is a special requirement for medical equipment. DC leakage current should be isolated separately and within 50uA limited which mentioned in medical safety standard. The function has already been added to the 6000-08 LC scanner.

Chroma 19032 + 6000-07/08 offer programmed edit and software support, let your test procedure of medical product not missing which save the test data directly to provide you the best test solution.

Main Test Item

- Open Short Check
- Ground Bond
- AC/DC Hipot Test
- Earth Leakage Current Test
- Enclosure LC
- Patient LC
- Patient Auxiliary LC

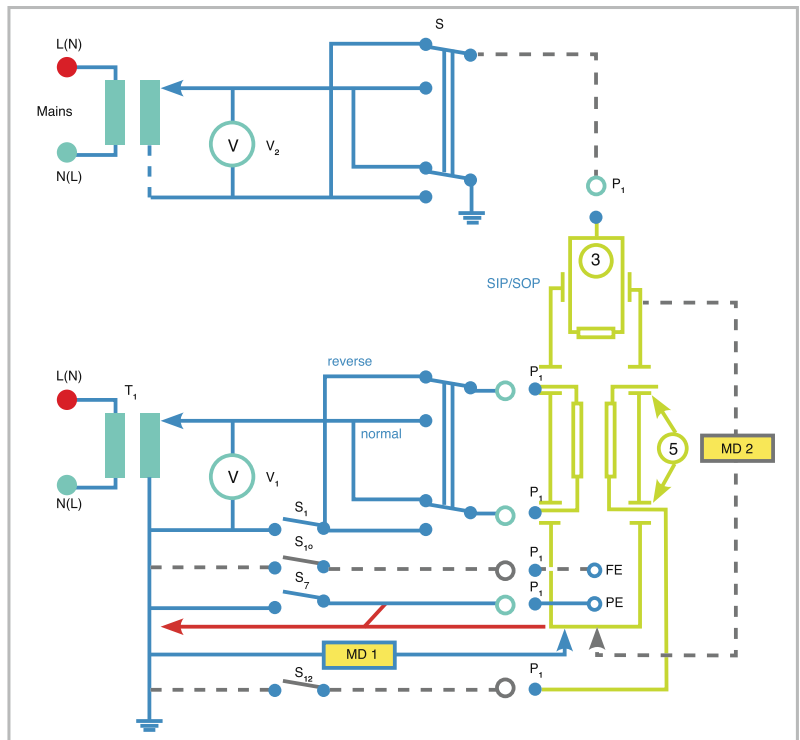

Refer to UL 60601-1 fig. 18 Measuring circuit for the Enclosure Leakage Current

TWINPORT™ HIPOT & GROUND BOND TEST FUNCTIONS (USA PATENT NO.: US6504381)

The 19032 electrical safety tester has Twinport™ Technology. This patented and unique feature allow testing Hi-pot test and ground bond test simultaneously, it can cut test time in half and ideal for production test.

Conventional Safety Analyzer	Ground Bond	Hipot
19032	Ground Bond Hipot	
	2 Sec.	2 Sec.

FLASHOVER DETECTION

The 19032 has Flashover Detection as other Chroma safety test series. Flashover is electricity transient or non-sequential discharge on inner or surface of insulation component which cause DUTs the original insulation feature loss, carbonation electrically conductive path generated and product damaged. Flashover can't be detected by leakage current, test voltage or shift rate of leakage current is required. Thus, Flashover Detection is one of inevitable inspection item in HV test.

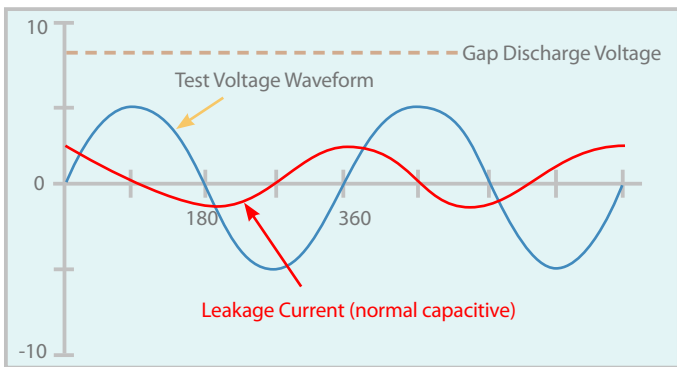

Figure 1 : Normal Leakage Current Waveform

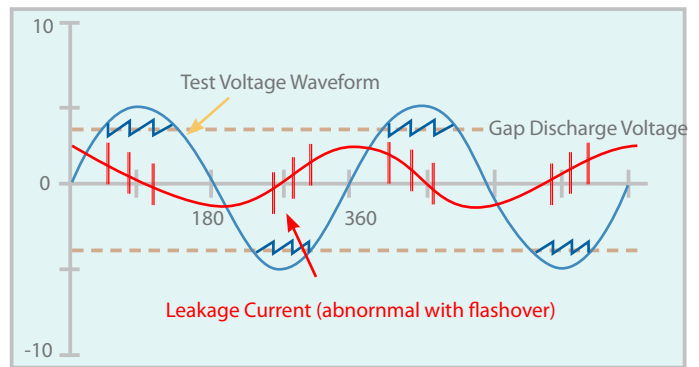

Figure 2 : Leakage Current Waveform when flashover occurred

OPEN / SHORT CHECK (OSC) (PATENT 254135)

OSC function is used to check the connection is open (bad contact) or short (DUT short) during the test procedure. When open occurred during test procedure, no good product will be judged as good product. When short occurred during test procedure, screening earlier to reduce the damage on equipment for saving test cost.

Generally speaking, the DUT has capacitive load (C_x) from tens to thousands pF under normal status. To form a micro capacitance on open circuit interface once connection interrupted (as C_c in figure 2). Generally speaking, the capacitance is lower than 10pF thus total capacitance is far lower than the status of normal product. The capacitance is far higher than normal status when DUT short or close to short. Therefore, users judge the short problem by using high/low limit value of capacitance change.

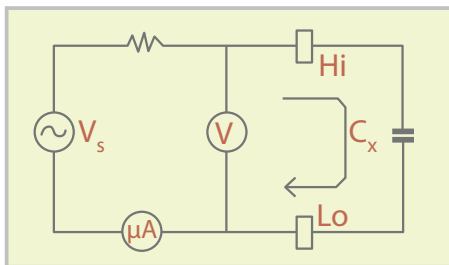

Figure 1 : Normal Connection

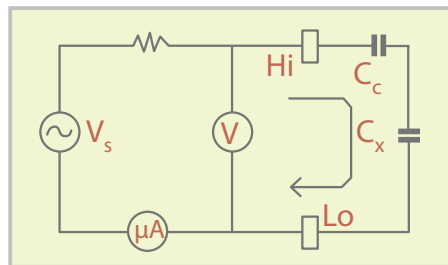

Figure 2 : Connection Open

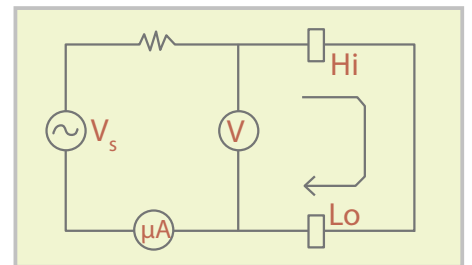

Figure 3 : Connection Short

CAPABILITY OF CONTROLLING CHROMA AC SOURCE (6400 / 61600 / 61500 SERIES)

The manufacturers apply Chroma AC Source for power supply in order to promote input voltage stability of dynamic leakage current test. The 19032 can use RS232 interface to control AC Source related models to let you more convenience in testing dynamic leakage current.



GFI HUMAN PROTECTION (19032-P)

The ultimate purpose of safety testing is protecting users from electric hazard. The 19032-P also has GFI function to protect operator. GFI function cut off the power output immediately while human body suffering electric shock. GFI function detects the current from Earth GND (Ioperator) and LOW terminal (Idevice). The voltage output will be cut off if the current is over 0.5mA.

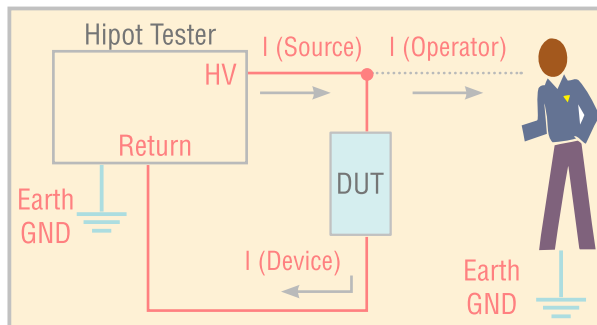

FLOATING CIRCUIT FUNCTION (19032-P)

Chroma develops Floating circuit by all new technology in order to let operator to use safety test equipment safely. Whatever the operator touches any Hipot test terminal under Floating status. The earth leakage current is lower than 3.5mA, the operator won't be hurt by electricity.

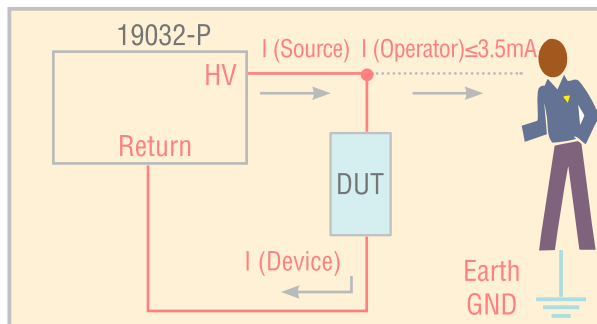

SUPPORT DYNAMIC LEAKAGE CURRENT TEST

The current brimmed after flow through insulation resistance, we called it as Leakage Current. When the leakage current contact with human body, the current flows to Earth via human body thus causes electric damage. The leakage current is testing under operating status. A human body RC network will be added in leakage current test, it can simulate the value of leakage current in real condition.

The leakage current has different test modes and standards in accordance with different safeties and test points. The most often seen current tests are Earth Leakage Current, Patient Leakage Current and Patient Slave Leakage Current.

The 19032 is used with different dynamic leakage current module and human body simulation equivalent circuit for the requirements of various safety modules. It can apply to Electrical Safety Testing of House Appliance, Video Product, Medical Equipment and etc.

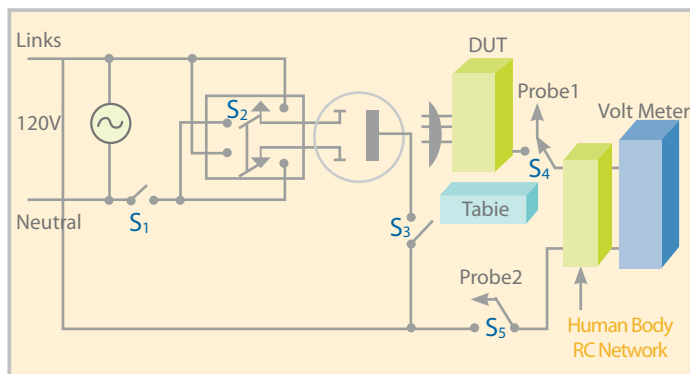

Input Hi Input Lo	Input Hi Input Lo	Input Hi Input Lo	Input Hi Input Lo	Input Hi Input Lo
UL 544 NON PATIENT	UL 544 PATIENT CARE	UL 1563 IEC 60335-1 IEC 601-1	UL 2601-1 IEC 60601-1	UL 1950 UL 3101-1 IEC 60950 IEC 1010

MASS POWER HIPOT OUTPUT TEST (19032-P)

The High Limit of Hipot test currently is often from 5 to 10mA. However, there is still a few of DUTs such as Safety Integrated Analyzer of EMI Filter or large-sized motor require mass power. The 19032-P promote the power of 19032 largely to let it equipped with the capabilities of outputting and measuring AC 100mA/DC 20mA.

Integrate Mass power Hipot test with other safety tests as a integrated analyzer for the users to use higher leakage current or large-sized electrical safety equipment. This brings the best efficiency to production line and quality assurance inspection.

The design of 500VA also comply with the requirement of IEC/UL output power to add the selection function of "don't be protected by trip circuit under short current 200mA and 100mA".



LEAKAGE CURRENT SCANNER

Different safety standards have various leakage current requirements which includes test method and max. current output. Chroma 19032 is able to combine different scanners for safety needs. List as below table.



Option			HIPOT		GB			LC				
No	Name	General Application	Ports	Voltage Max	Ports	Current Max	Power Output	LC Probe	Earth LC	Touch LC	Patient LC	Patient Aux LC
A190301	9030A (Ext.)	customized	8 ports	5KVac 6KVdc	-	-	-	-	-	-	-	-
A190302	6000-01	customized	5 ports		3 ports	30A	-	-	-	-	-	-
A190303	6000-02	customized	3 ports		5 ports	30A	-	-	-	-	-	-
A190304	6000-03	customized	8 ports		-	-	-	-	-	-	-	-
A190305	6000-04	IT product House appliance	L+N to E P to S		-	-	300V/10A	-	●	-	-	-
A190306	6000-05	Lab/TN			-	-	300V/10A	P1&P2	●	●	●	●
A190308	6000-07	Medical equipment			-	-	300V/20A	P1&P2	●	●	●	●
A190350	6000-08*	Special Medical Audio & Video			-	-	300V/20A	P1&P2	●	●	●	●
A190307 A190309 A190342	6000-06 EMI Filter Test Fixture	-	L+N to E L to N		2 ports	30A	-	-	-	-	-	-

OPTIONAL FIXTURE

Chroma provides related test optional fixture for test requirement of different customers.

- **Isolating Transformer** : The isolating transformer is auxiliary and DUT floating connected while performing leakage current test. The above are described in the safety standard.
- **Dummy Load** : The main function of the fixture is to confirm the normality of the instrument before daily power on.
- **Bar-code Scanner** : It can connect with 19032 directly.
- **Current Transformer** : It is able to rise ground bond test to 40A or 60A.
- **Universal Corded Product Adapter** : By using this adapter to perform test directly for various types of plug in different countries.



Isolating Transformer



Dummy Load



Current Transformer



Universal Corded Product Adapter

EST SOFTWARE / EST PROFESSIONAL

EST software can control Chroma 19032 to perform electrical safety integrated test. Having EST software, you can save test procedure and data directly as well as converting to EXCEL file for the convenience of management and statistical analysis.

- Program edit and GO/NG control
- Data bank
- Report function
- Statistical analysis function
- Authority management function

EST software professional is capable of controlling Chroma 19032 & 19200 simultaneously, it lets multi channels scanning become your best tool in testing.

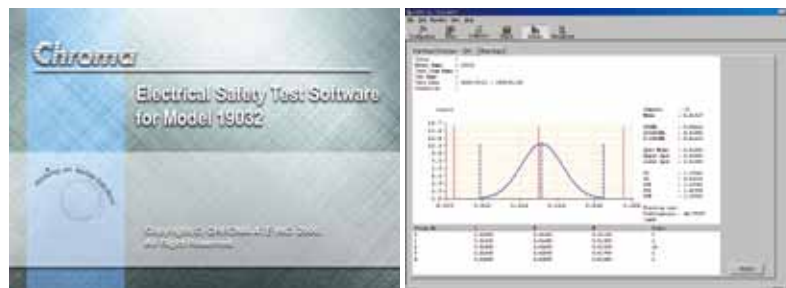

SYSTEM INTEGRATED APPLICATION (8900 ELECTRICAL EQUIPMENT ATS)

19032 can be integrated to Chroma 8900 electrical equipment ATS directly. 8900 electrical equipment ATS is the solution for solving electrical safety test and special function test. The system can combine different testers in the system according to different test requests what you need.

- Open Architecture
- Procedure edit and GO/NG Control
- Data bank and powerful auto report function
- Statistical analysis function
- Authority management function

Management of various types of different test reports and operation that these functions are indispensable for quality control and production line testing in a modern electrical manufacturer.

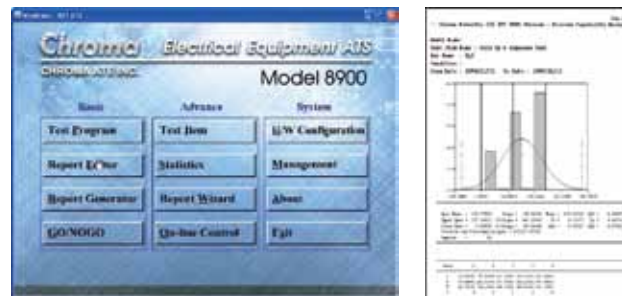

PANEL DESCRIPTION

1. Power Switch
2. LCD Display
3. Stop Key
4. Start Key
5. Cursor Keys
6. TEST Key
7. PRINT Key
8. SYSTEM Key
9. Cal-Enable (19032)
10. DATA Entry Key
11. Function Key
12. HV Output
13. DRIVE+
14. SENSE+
15. SENSE-
16. DRIVE-
17. Update Enable (19032)
18. Remote I/O

19032

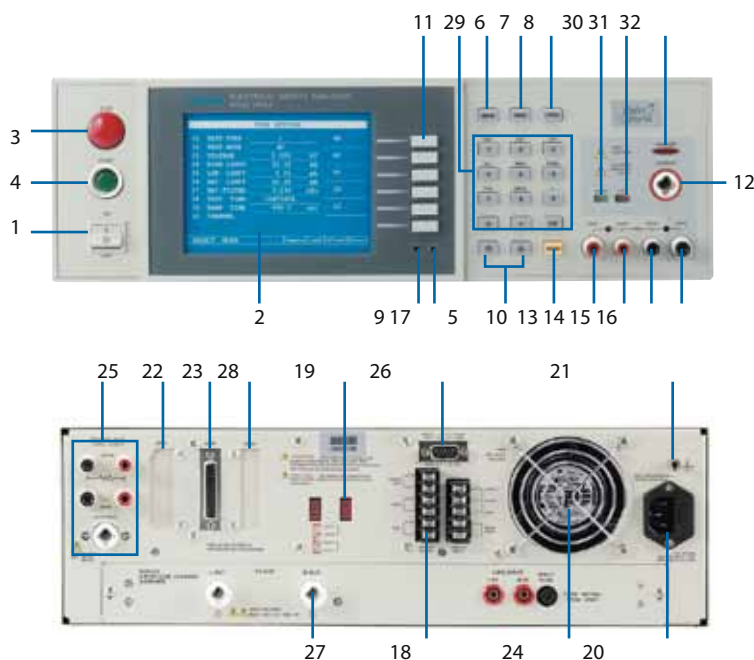

19. Line Voltage Selector
20. Power Cord Receptacle
21. GND Terminal
22. GPIB Interface
23. SCAN Interface
24. Fan
25. Rear Panel Output
26. I/O Control (9 pin)
27. Scan Box
28. RS232 Interface
29. Data Entry Keys/Program Keys
30. PASS Indicator
31. FAIL Indicator
32. DANGER Indicator
33. Floating Output (19032-P)
34. USB Interface (19032-P)

19032-P

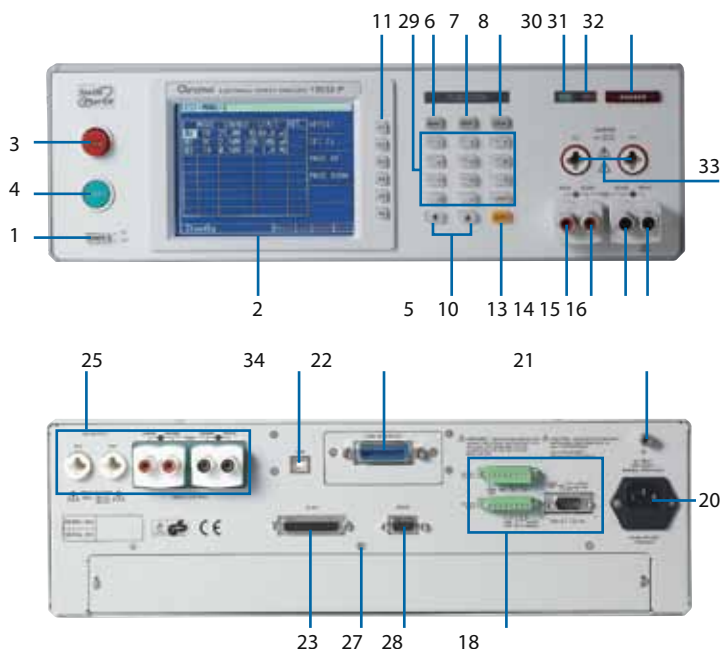

SPECIFICATIONS

Model	19032	19032-P
Mode	AC/DC/IR/GB/LC	
Withstanding Voltage Test		
Output Voltage	DC:0.05 ~ 6kV , AC : 0.05 ~ 5kV	
Load Regulation	±(1% of reading +0.1% of range)	±(1% of reading +0.1% of range)
Voltage Regulation	2V	
Voltage Accuracy	±(1% of reading +0.1% of range)	±(1% of reading +0.1% of range)
Cutoff Current	DC : 20mA , AC : 40mA	DC : 20mA , AC : 100mA
Current Resolution	0.1 µA DC	
Current Accuracy	±(1% of reading +0.1% of range)	±(1% of reading +0.1% of range)
Output Frequency	50Hz / 60Hz	
Test Time	0.3 ~ 999 sec , continue	
Ramp Time	0.1 ~ 99.9 sec, Off	
Fall Time	0.1 ~ 99.9 sec, Off	
Waveform	Sine wave	
Insulation Resistance Test		
Output Voltage	DC : 0.05 ~ 1kV	
Voltage Resolution	2V	
Voltage Accuracy	±(2% of reading +0.5% of range)	±(2% of reading +0.5% of range)
IR Range	1MΩ ~ 50GΩ	
Resistance Resolution	0.1MΩ	
Resistance Accuracy	5% typical	
Ground Bond Test		
Output Current	AC : 1 ~ 30A	AC : 3 ~ 40A
Current Accuracy	±(1% of reading +0.2% of range)	±(1% of reading +0.2% of range)
GR Range	10mΩ ~ 510mΩ	
Resistance Resolution	0.1mΩ	
Resistance Accuracy	± (1% of reading + 0.1% of full scale)	± (1% of reading + 0.1% of full scale)
Test Method	4 wires	
Flashtest Detection		
Setting Mode	Programmable setting	
Detection Current	AC : 20mA, DC : 10mA	
Secure Protection Function		
Ground Fault Interrupt	-	0.5mA ±0.25mA AC
Floating Output	-	3.5mA, front output only
Panel Operation Lock	Present password	
Interlock	YES	
GO/NG Judgment Window		
Indication,Alarm	GO : Short sound,Green LED ; NG : Long sound, Red LED	
Data Hold	Least tests data memories	
Memory Storage	50 setups with up to 100 groups recall	
Interface		
9pin D-sub I/O control / RS232 / GPIB (Optional)		
General		
Operation Environment	Temperature : 0°C ~ 40°C, Humidity : ± 80 % RH	
Power Consumption	No load : < 100 W With rated load : 800 W	No load : < 100W Rated load : 1000W Maximum load : 1200W
Power Requirements	90~132Vac or 198~264Vac, 47~66Hz	
Weight	Approx. 20KG(19032) 25KG (19032-P)	

Option	6000-04 ~ 08*
Support Mode	AC/DC/IR/LC
DUT Input Power Capacity	AC : 300V / 10A / 20A max.
Short Protection	20A, 250V fuse for DUT shorted.
Measurement Mode	
Input Characteristic	DC - 1MHz Input Impedance : 1M//20pF
Measurement Mode	Normal, Reverse, Single Fault Normal, Single Fault Reverse
Measurement Devices (Five measure device)	UL 544 NP ; UL 544 P UL 1563 ; UL 60601-1, IEC60601-1; UL 3101-1, UL/IEC 60950, UL 1950-U1* ; UL 2601-U1* IEC60990
Probe Connection	Line to Ground, Line to P2, P1 to P2
HI-LO Limit	
LC HI-LO Limit	0 ~ 9.99mA, 1µA resolution
Current HI-LO Limit	0 - 19.99Amp*
VA HI-LO Limit	0 - 4400VA
VA Resolution	0.1VA

*Different option have different specification.

ORDERING INFORMATION

19032 : Electrical Safety Analyzer
 19032-P : Electrical Safety Analyzer (500VA)
 A190301 : 8HV Scanning Box
 A190302 : 5HV/3GC Scanner
 A190303 : 3HV/5GC Scanner
 A190304 : 8HV Scanner
 A190305 : Line Leakage Current Scanner (generally)
 A190306 : Hipot/Line Leakage/Probe Scanner (10A)
 A190307 : L-N Scanner & Leakage Current Scanner
 A190308 : Hipot/Line Leakage/Probe Scanner (20A)
 A190313 : 500VA Isolation Transformer
 A190314 : 1000VA Isolation Transformer
 A190316 : Dummy Load
 A190317 : Bar Code Scanner
 A190321 : GPIB Interface
 A190334 : Ground Bond 40A
 A190337 : Ground Bond 60A
 A190338 : 19001 EST Software
 A190309 : EMI FILTER Scanner
 A190342 : EMI FILTER Test Box
 A190343 : 19" Rack Mount Kit for Model 19032
 A190344 : HV Gun
 A190349 : Universal Corded Product Adapter
 A190708 : ARC Verification Fixture

*All specifications are subject to change without notice.

Developed and Manufactured by :

CHROMA ATE INC.

致茂電子股份有限公司

HEADQUARTERS

66, Hwa-Ya 1st Rd., Hwa-Ya
 Technology Park, Kuei-Shan Hsiang,
 Taoyuan Hsien 33383, Taiwan
 Tel: +886-3-327-9999
 Fax: +886-3-327-8898
 http://www.chromaate.com
 E-mail: chroma@chroma.com.tw

U.S.A.

CHROMA SYSTEMS SOLUTIONS,
 INC. (U.S.A.)
 25612 Commercentre Drive
 Lake Forest, CA 92630-8830
 Tel: +1-949-600-6400
 Fax: +1-949-600-6401
 Toll Free: +1-866-600-6050
 http://www.chromausa.com

EUROPE

CHROMA ATE EUROPE B.V.
 Morsestraat 32, 6716 AH Ede,
 The Netherlands
 Tel: +31-318-648282
 Fax: +31-318-648288

CHINA

CHROMA ELECTRONICS
 (SHENZHEN) CO., LTD.
 8F, No.4, Nanyou Tian An
 Industrial Estate, Shenzhen,
 China PC: 518054
 Tel: +86-755-2664-4598
 Fax: +86-755-2641-9620

Distributed by:

Worldwide Distribution and Service Network

19032-E-200912-PDF