

6½ Digital Multimeter

MODEL 12061



6½ DIGITAL MULTIMETER MODEL 12061

Solution for General Instrument Measurement
6½ Digital Multimeter is the most frequent used measurement instrument in Electronic industry. Chroma 12061 provides a combination of speed, accuracy and high performance measurement functions that can be used either solely or with system to meet your requirements swiftly.

Chroma 12061 offers the resolution and specification of the same class in the industry plus enhanced speed and accuracy it turns into the best solution for various kind of basic measurements. A brand new designing was made for the operating interface of Chroma 12061. The commonly used functions can be selected with a single button press that increases the panel accessibility greatly.

Fast & High Performance

The 12061 6½ Digital Multimeter has assorted settings of resolution, integration time and ranges that allow users to optimize the configuration of measurement speed, resolution

and accuracy when in individual measurement test mode.

The 12061 has built-in a high speed, low interference A/D converter with a maximum speed of 2000 rdgs/s it is the best solution for high speed measurement.

Individual Application

Chroma 12061 equipped with 11 types of measurement functions containing DC voltage/current, AC voltage/current, resistance 2/4-wire ohms, period, frequency, diode, continuity and temperature as well as diverse math functions of NULL, Max/Min/Avg, High/Low limit, High/Low limit, Percentage/Ratio/MX+B, dB/dBm and etc. Along with trigger and memory function, Chroma 12061 is the right tool for you to perform the basic measurement.

Test System Application

For user's convenience Chroma supports various software for different control platforms.

Specifications:

- 6½ digits resolution
- 11 types of measurement characteristics
 - DC voltage/current (1000V/3A max)
 - AC voltage/current (750V/3A max)
 - Resistance 2 or 4-wire ohms measurement
 - Period & frequency
 - Diode & continuity
 - Temperature (Thermocouple & RTD)
- Various math functions
 - NULL
 - Max/Min/Avg
 - High/Low limit
 - Percentage/Ratio/ MX+B
 - dB/dBm
- DC voltage accuracy : 0.0015%
- AC voltage accuracy : 0.04%

Key Features:

- Built-in USB (USBTMC supported)
- PASS/FAIL signal output
- Optional Multi-point Scanner Card (10ch)
- Measurement and data transmission up to 2000 readings/sec (4½)
- Up to 2000 readings memory storage
- Standard SCPI control
- Optional GPIB interface
- Software control support

Chroma



BUILT-IN USB (USBTMC SUPPORTED)

Different from the traditional interface, Chroma 12061 uses USB as its standard feature that not only improves the transmission speed but also makes the connection more easier with the plug and play function.

The USB interface fully supports USBTMC (USB Test & Measurement Class). As long as the instrument is equipped with USB interface that supports USBTMC, it can communicate with PC in real time via VISA driver without the restrictions of platform and environment. USBTMC is a communication protocol built on top of the USB and uses GPIB-like methodology to communicate with USB. Therefore, from user's point of view using USB should be as simple as using GPIB.

PASS/FAIL SIGNAL OUTPUT

Chroma 12061 can provide PASS/FAIL signal to system by USB port (either communication or PASS/FAIL signal) with high/low limit set. USB type B female connect to system with signal (1 floating/ 2 PSS/ 3 FAIL/ 4 GND) in 2ms low and please disable USB interface. If result over the high/low limit, the beeper will alarm and signal output. (Beeper can be off)

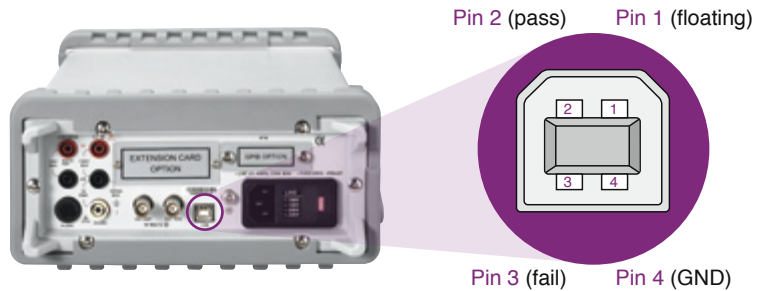

TEMPERATURE MEASUREMENT

Chroma 12061 has temperature measurement function that supports 7 kinds of Thermocouples: E, J, K, N, R, S, and T type. It also supports RTDs 4-wire measurement. The built-in ITS-90, IEC751 and Callendar-Van Dusen temperature conversion can satisfy the diverse measurement requirements of yours.

MULTI-POINT SCANNER CARD

Chroma 6½ Digital Multimeter supports Multi-point Scanner Card which is a scanning measurement tool not supported by most of the 6½ Digital Multimeters in the field.

Multi-point Scanner Card offers multiplexing ten two poles (ACV, ACI, DCV, DCI, Resistance, Period, Frequency) that can be installed to the extension card option directly on the rear panel.



A120000 Multi-point Scanner Card

SPECIFICATION	
Model	A120000
Maximum AC Voltage	125V rms or 175V peak, 100kHz, 1A switched, 62.5VA (resistive load)
Maximum DC Voltage	110V, 1A switched, 30VA (resistive load)
Contact Life	>100000 operations at maximum signal level; >100000000 operations cold switching.
Contact Resistance	<1ohm at end of contact life
Actuation Time	5ms maximum on/off
Contact Potential	<± 500nV typical per contact, 1 μV max <± 500nV typical per contact pair, 1 μV max
Connector Type	Screw terminal, #22 AWG wire size
Isolation btw Any Two terminals	>10 Gohm, < 75pF
Isolation btw Any Terminal and Earth	>10 Gohm, < 150pF
Common Mode Voltage	350V peak btw any terminal and earth
Max. Voltage btw Any Two Terminals	200V peak
Max. Voltage btw Any Terminal and M3500A Input LO	200V peak
Environmental	Meets all 12061 Environmental Spec.

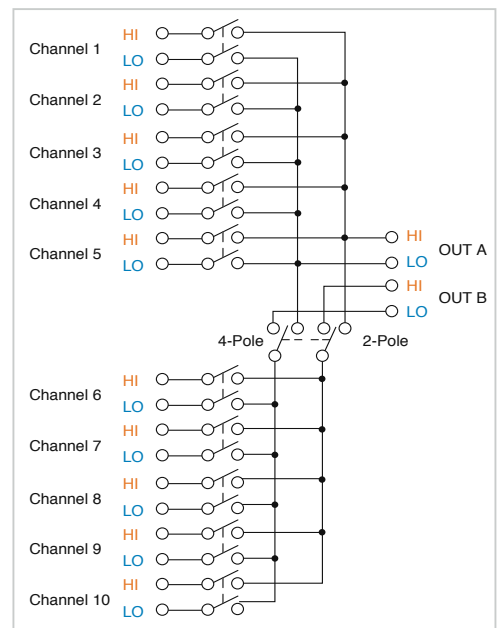

A120000 Scanner Card Configuration

OPERATION SPEED (INDIVIDUAL)

DCV、DCI and Resistance	6½ SLOW	5.9 reading/s
	6½ FAST	59 reading/s
	5½ SLOW	59 reading/s
	5½ FAST	545 reading/s
	4½ SLOW	545 reading/s
	4½ FAST	2000 reading/s

ACV、ACI	6½ SLOW	0.15 reading/s (3Hz)
	6½ MEDIUM	1 reading/s (3Hz)
	6½ FAST	10 reading/s (200Hz)
Frequency or Period	6½	1 reading/s
	5½	9.8 reading/s
	4½	80 reading/s
Diode / Continuity	Response time	300 reading/s

SOFTPANEL

Chroma 12061 TOOL and Chroma 12061 LINK are two free softpanel with 12061 which provided data collection and drawing for analysis.

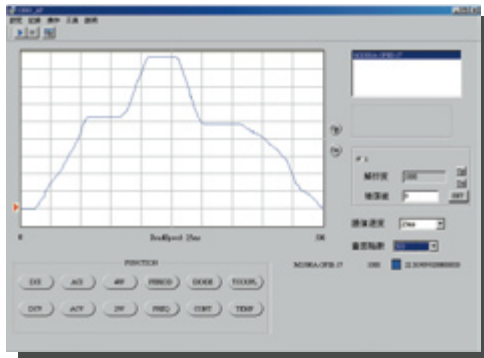

CHROMA 12061 TOOL

- Real-time display interface for value monitoring
- data log and output in CSV format for analysis

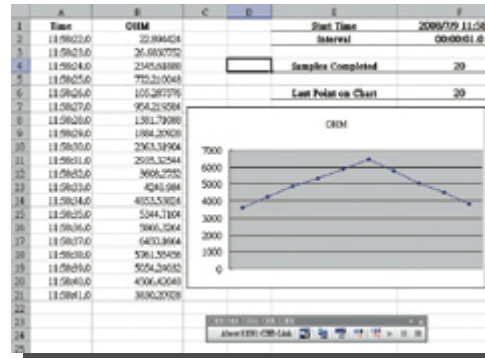

CHROMA 12061 LINK

- softpanel toolbar open with EXCEL or WORD
- send the data to PC directly in real time and save it to EXCEL or WORD format
- Auto create the data pattern in EXCEL format
- Test engineers can use ActiveX components to control the 12061 using SCPI commands

PANEL DESCRIPTION



- Easy-to-read display with 5X7 matrix triple colored double-line screen that can identify the meaning of data and symbol easily
- Easy-to-switch function keys
- 2 or 4-wire ohms measurement
- Built-in frequency, diode, continuity and temperature measurement capability

- Fast TRIGGER control
- Data storage memory
- Math calculation
- Fast range changes
- Optional Scanner Card
- USB Interface supports USBTMC
- GPIB Interface

- 7A/250V Fuse
- Measurement completed signal output terminal for automatic operation
- External triggered input terminal for automatic operation

SPECIFICATIONS

DC Voltage			
Range	Resolution	Input Resistance	1 year accuracy \pm (reading%+range%) (23°C \pm 5°C)
100.000mV	0.1 μ V	>10G Ω	0.0050 + 0.0035
1.000000V	1.0 μ V		0.0040 + 0.0007
10.00000V	10 μ V		0.0035 + 0.0005
100.0000V	100 μ V	10M Ω	0.0045 + 0.0006
1000.000V	1mV		0.0045 + 0.0010
DC Current			
Range	Resolution	Shunt Resistance	1 year accuracy \pm (reading%+range%) (23°C \pm 5°C)
10.00000mA	10nA	5.1 Ω	0.050 + 0.020
100.0000mA	100nA		0.050 + 0.005
1.000000A	1 μ A	0.1 Ω	0.100 + 0.010
3.00000A	10 μ A		0.120 + 0.020
AC RMS Voltage			
Range	Resolution	Frequency (Hz)	1 year accuracy \pm (reading%+range%) (23°C \pm 5°C)
100.0000mV	0.1 μ V	3 ~ 5	1.00 + 0.04
		5 ~ 10	0.35 + 0.04
		10 ~ 20K	0.06 + 0.04
		20K ~ 50K	0.12 + 0.05
		50K ~ 100K	0.60 + 0.08
1.000000V ~ 750.000V	1.0 μ V ~ 1mV	100K ~ 300K	4.00 + 0.50
		3 ~ 5	1.00 + 0.03
		5 ~ 10	0.35 + 0.03
		10 ~ 20K	0.06 + 0.03
		20K ~ 50K	0.12 + 0.05
50K ~ 100K	0.60 + 0.08		
100K ~ 300K	4.00 + 0.50		
AC RMS Current			
Range	Resolution	Frequency (Hz)	1 year accuracy \pm (reading%+range%) (23°C \pm 5°C)
1.000000A	1 μ A	3 ~ 5	1.00 + 0.04
		5 ~ 10	0.30 + 0.04
		10 ~ 5K	0.10 + 0.04
3.000000A	1.0 μ A	3 ~ 5	1.10 + 0.06
		5 ~ 10	0.35 + 0.06
		10 ~ 5K	0.15 + 0.06
Resistance (4W Measurement)			
Range	Resolution	Test Current	1 year accuracy \pm (reading%+range%) (23°C \pm 5°C)
100 Ω	100 μ Ω	1mA	0.010 + 0.004
1.000000k Ω	1m Ω	1mA	0.010 + 0.001
10.00000k Ω	10m Ω	100 μ A	0.010 + 0.001
100.0000k Ω	100m Ω	10 μ A	0.010 + 0.001
1.000000M Ω	1 Ω	5 μ A	0.010 + 0.001
10.00000M Ω	10 Ω	500nA	0.040 + 0.001

ORDERING INFORMATION

12061 : 6½ Digital Multimeter

A120000 : Multi-point Scanner Card

A120001 : Thermal-measurement Adapter

Diode Test			
Range	Resolution	Test Current	1 year accuracy \pm (reading%+range%) (23°C \pm 5°C)
1.00000V	10 μ V	1mA	0.010 + 0.020
Continuity Test			
Range	Resolution	Shunt Resistance	1 year accuracy \pm (reading%+range%) (23°C \pm 5°C)
1000.00 Ω	100m Ω	1mA	0.010 + 0.030
Frequency and Period			
Range	Frequency (Hz)	1 year accuracy \pm (reading%+range%) (23°C \pm 5°C)	
100mV ~ 750V	3 ~ 5	0.1	
	5 ~ 10	0.05	
	10 ~ 40	0.03	
	40 ~ 300K	0.01	
Measurement Characteristics			
Math Functions	NULL, min / max / average, dBm, dB, MX+B, RATIO, %, limit test (with TTL output)		
Measurement Noise Rejection 60Hz(50Hz)	DC CMRR : 140 dB AC CMRR : 70 dB		
Integration Time & Normal Mode Rejection NMRR	10 plc / 167 ms (200 ms) : 60 dB 1 plc / 16.7 ms (20 ms) : 60 dB		
DC Voltage	Input bias current : 25°C < 30pA Input protection : 1000V		
DC Current	Input protection: External 3 A 250V fuse		
AC Voltage	Input impedance: 1 M Ω parallel with 100 pF Input protection: 750Vrms all ranges		
AC Current	Input protection: External 3 A 250V fuse		
Resistance	Maximum lead resistance (4-wire): 10% of range per lead for 100 Ω and 1k Ω ranges. 1k Ω per lead on all other ranges. Input protection: 1000 V all ranges		
Continuity/Diode	With audible tone Continuity threshold: Selectable from 1 Ω to 1000 Ω		
Temperature	Thermocouple: E, J, K, N, R, S and T type sensors supported. RTD: 2-wire, 3-wire and 4-wire measurement Temperature Conversion: ITS-90, IEC751, Callendar-Van Dusen		
External Control			
Samples/Trigger	1 ~ 50,000		
Trigger Delay	0 ~ 3600 sec.		
Memory	2000 readings		
Standard Complier	SCPI (IEEE-488.2) \ Agilent 34401		
Interface	USB (standard) \ GPIB (option)		
General			
Power Consumption	25VA max.		
Power Requirements	100 V / 120 V / 220 V / 240 V \ 45 Hz ~ 440 Hz		
Operation Environment	8.5(H) x 21(W) x 35(D) cm		
Weight	Approx. 4.36 kgs		

All specifications are subject to change without notice.

Developed and Manufactured by :

CHROMA ATE INC.

致茂電子股份有限公司

HEADQUARTERS

66, Hwa-Ya 1st Rd., Hwa-Ya
Technology Park, Kuei-Shan Hsiang,
Taoyuan Hsien 333, Taiwan
Tel: +886-3-327-9999
Fax: +886-3-327-8898
http://www.chromaate.com
E-mail: chroma@chroma.com.tw

U.S.A.

CHROMA ATE INC. (U.S.A.)
7 Chrysler Irvine, CA 92618
Tel: +1-949-421-0355
Fax: +1-949-421-0353
Toll Free: +1-800-478-2026

EUROPE

CHROMA ATE EUROPE B.V.
Morsestraat 32
NL-6716 AH Ede
The Netherlands
Tel: +31-318-648282
Fax: +31-318-648288

CHINA

**CHROMA ELECTRONICS
(SHENZHEN) CO., LTD.**
8F, No.4, Nanyou Tian An
Industrial Estate, Shenzhen,
China PC: 518054
Tel: +86-755-2664-4598
Fax: +86-755-2641-9620

Distributed by:

Worldwide Distribution and Service Network

12061-E-200808-PDF